



Instruction manual



2026-04-30

**Meat mincer 1 grinding group
removable grinding unit 300 kg/h 230 V
TE 22 EM**

www.rmgastro.com



TABLE OF CONTENTS

1. DECLARATION OF CONFORMITY	3
2. TECHNICAL DATA	3
3. LOCATION ELECTRIC	3
4. SAFETY MEASURES FOR FIRE PROTECTION	3
5. INSTALLATION	4
6. CONNECTING THE ELECTRICAL CABLE TO THE NETWORK	4
7. INSTRUCTIONS FOR USE	6
8. CLEANING AND MAINTENANCE	11

1. DECLARATION OF CONFORMITY

Decree of the Ministry of Health of the Czech Republic no. 38/2001 Coll. of 19 January 2001 Regulation (EC) No 1907/2006 - Registration, Evaluation, Authorisation and Restriction of Chemicals (REACH) Regulation of the European Parliament and Council Regulation (EC) no. 1935/2004 of 27 October 2004

The products meet the requirements of §26 of Act No.258/2000 as amended. The products meet the requirements of RoHS Directive 2015/863/EU, 10/2011, 517/2014, 2015/1094, 2015/1095.

Attention, the manufacturer gives up any responsibility in case of direct and indirect damage that is relate to poor installation, incorrect intervention or adjustments, insufficient maintenance, incorrect by using and which are eventually caused by other causes that the points referred to in the conditions sales. This appliance is intended only for professional use and must be operated by qualified by persons. Parts that have been secured by the manufacturer or authorized worker after the setting rebuild.

2. TECHNICAL DATA

The label with technical data is located on the side or back panel of the device. Please read the wiring diagram and all the following information in the attached manual before installation.

Net Width [mm]	Net Depth [mm]	Net Height [mm]	Net Weight [kg]	Power electric [kW]	Loading
290	520	520	25.00	1.100	230 V / 1N - 50 Hz

3. LOCATION ELECTRIC

For the correct operation and placement of the appliance, it is necessary to observe the following all prescribed standards for the given market. Unpack the device and check that the device has not been damaged during transport. Place the device on a horizontal surface (maximum unevenness up to 2°). Small unevenness can be leveled with adjustable feet. If the device will be placed in such a way that it will be in contact with the walls of the furniture, these must withstand a temperature of up to 60°C. Installation, adjustment, commissioning must be performed by a qualified person who is authorized to perform such operations, according to applicable standards. The device can be installed separately or in series with devices of our production. A minimum distance of 10 cm from flammable materials must be observed. In this case, it is necessary to secure the appropriate modifications to ensure the thermal insulation of the combustible parts. The appliance must only be installed on a non-flammable surface or against a non-flammable wall. **Parts of the appliance provided by the manufacturer. or his representative, the worker performing the installation may not rebuild the product.**

4. SAFETY MEASURES FOR FIRE PROTECTION

- the appliance may only be operated by adults
- the appliance may be used safely in accordance with applicable market standards:

Fire protection in spaces with special risk or danger

Protection against the effects of heat

- the appliance must be placed so that it stands or hangs firmly on a non-combustible surface

Objects of flammable substances must not be placed on the appliance at a distance less than a safe distance from it (the smallest distance between the appliance and flammable substances is 10 cm).

Table: degree of flammability of building materials included in st. flammability of substances and products

Degree of flammability	Building materials
A - non-flammable	granite, sandstone, concrete, brick, ceramic tiles, plaster
B - Not easily flammable	Acumin, Heraclitus, Lihnos, Itaver
C1 - highly flammable	wood, hardwood, plywood, hard paper, umakart
C2 - moderately flammable	chipboards, solodur, cork boards, rubber, flooring
C3 - Highly flammable	wood fiber boards, polystyrene, polyurethane, PVC

- information on the degree of flammability of common building materials is given in the table above. Appliances must be installed in a safe manner. During installation, the relevant design, safety and hygiene regulations must also be respected:
- fire safety of local appliances and heat sources
- fire protection in areas with special risk or danger
- protection against the effects of heat

5. INSTALLATION

Important: The manufacturer does not provide any warranty for defects arising as a result of incorrect use, failure to follow the instructions contained in the attached user manual and mishandling of appliances. Installation, modification and repair of appliances for large kitchens, as well as their dismantling due to possible damage to the gas supply, can only be carried out on the basis of a maintenance contract, this contract can be concluded with an authorized dealer, while technical regulations and standards and regulations must be observed regarding installation, electrical supply, gas connection and work safety. Technical instructions for installation and adjustment, for use by specialized technicians ONLY. The instructions that follow refer to a technician qualified for installation to carry out all operations in the most correct manner and according to the applicable standards. Any activity related to regulation etc. must only be performed with the device disconnected from the network. If it is necessary to keep the appliance under voltage, the utmost care must be taken. The type of appliance for extraction is declared on the nameplate, it is an A1 appliance.

6. CONNECTING THE ELECTRICAL CABLE TO THE NETWORK

Installation of the electrical supply - this supply must be separately secured. Ato with the corresponding circuit breaker of rated current depending on the power input of the installed device. Check the power consumption of the device on the production label on the back panel (or side) of the device. The connected ground wire must be longer than the other wires. Connect the device directly to the network, it is necessary to insert a switch between the device and the device with a minimum distance of 3 mm between the individual contacts, which corresponds to the applicable standards and load. The earth supply (yellow-green) must not be interrupted by this switch. Connect the device to the mains if the socket has adequate protection. In any case, the supply cable must be located so that it does not reach a temperature of 50 degrees higher than the environment at any point. Before the appliance is connected to the network, it is necessary to first make sure that:

- the supply circuit breaker and the internal distribution can withstand the current load of the appliance (see matrix label)
- the distribution board is equipped with effective grounding according to the standards of the relevant market and the conditions given by law
- the socket or switch in the supply is easily accessible from the appliance
- the electrical supply to the device must be made of oil-resistant material

We disclaim any responsibility in the event that these standards are not respected and in the event of a violation of the above principles. Before first use, you must clean the device, see chapter "cleaning and maintenance". The appliance must be grounded using a screw with a grounding mark.

- Do not insert the plug of the power supply into the electrical outlet. sockets and do not pull out the zel. sockets with wet hands and pulling on the power cord!
- Do not use extension cords or multiple sockets.
- **The mains connection point must have a maximum of the following impedance: $Z_{MAX} = 0.042 + j 0.026 \Omega$ for the phase conductors and $0.028 + j 0.017 \Omega$ for the neutral conductor.**

Models	Production (kg)	Engine speed (rpm)	Knife speed (rpm)	Voltage (V)	Power input (kW)	Coverage	Noise (dB)	Dimension (cm)	Weight (kg)
T-8	50	1 400	245	230	0,37	IP 44	70	28 x 27 x 34 v	8,5

S-12	160	1 400	220	230 / 400	0,75	IP 44	70	54 x 25 x 43 v	20
TS-12 / TS-12D	160	1 400	220	230 / 400	0,75	IP 44	70	40 x 29 x 47 v	18
TE-22 / TE-22D	300	1 400	174	230 / 400	1,1	IP 44	70	45 x 29 x 48 v	25
TE-22 ET	80/h	1 400	174	230 / 400	1,1	IP 44	70	45 x 29 x 48 v	25
TE-22 EM	60/h	1 400	174	230 / 400	1,1	IP 44	70	45 x 29 x 48 v	25
TS-22 / TS-22D	300	1 400	174	230 / 400	1,1	IP 44	70	30 x 42 x 50 v	39
TS-32 / TS-32D	500	1 400	160	230 / 400	2,2	IP 44	70	32 x 48 x 55 v	43

Fig. 1

A) Engine body

B) Engine base

C) Grinding chamber complete

D) Control panel

E) Hopper

F) Pressure pin

G) Production label

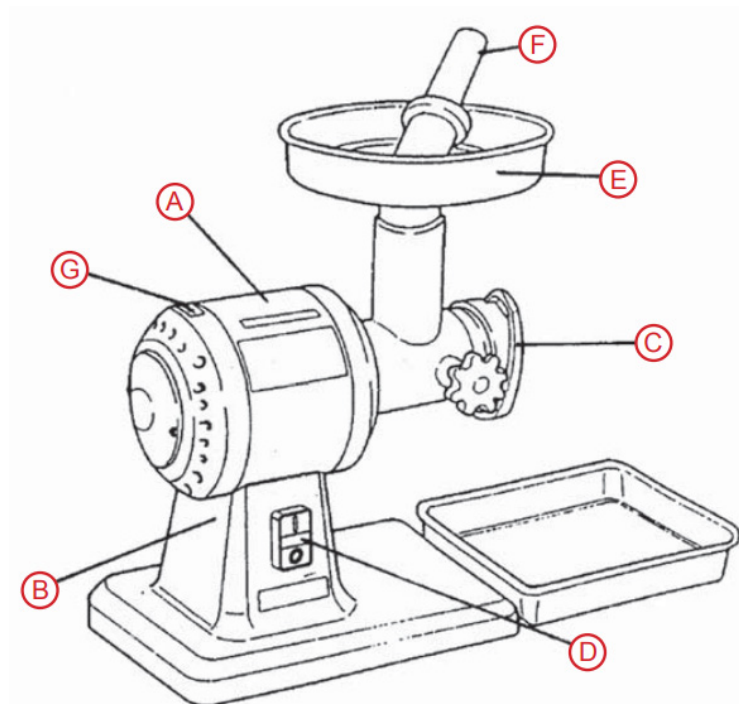

Connecting the power cable to the mains

Installation of the electrical supply - This supply must be separately fused with an appropriate circuit breaker of rated current depending on the power input of the installed appliance. Check the nameplate for the wattage of the appliance.

Connect the appliance directly to the mains using the plug on the power cord. If the appliance is connected to the mains using a supply cable without a plug, it is necessary to insert a switch between the appliance and the mains with

a minimum distance of 3 mm between the contacts, corresponding to the applicable standards and loads.

The earth lead (yellow-green) must not be interrupted by this switch.

In any case, the supply cable must be positioned so that at no point does it reach a temperature 50 degrees above ambient. Before the appliance is connected to the mains it is necessary to make sure that:

- the supply circuit breaker and the internal wiring can withstand the load of the appliance (see matrix label)
- the distribution system is equipped with an effective grounding according to the standards (CSN) and conditions given by law
- the socket or switch in the supply is easily accessible from the appliance

We disclaim any liability in the event that these standards are not adhered to and in the event of a breach of the above principles.

Before first use, the protective film must be removed from the instrument and the instrument cleaned, see chapter

„Cleaning and maintenance“.

7. INSTRUCTIONS FOR USE

Attention! Before using the appliance, it must be washed well with dishwashing liquid and detergent, then rinsed with clean water. Never leave the appliance running unattended.

The device is designed for grinding meat and with a special attachment also for pasteurizing tomatoes.

The equipment may only be used by persons familiar with the operating instructions and authorised to operate the equipment.

Cut the meat to be ground into cubes of a size that allows them to fall freely through the hopper into the grinding area. Place the prepared meat in the hopper, prepare a bowl for the processed meat under the outlet of the grinding compartment and start the grinder by pressing the green button and pushing the pin to gently push the meat into the grinding compartment. Never push the meat without using the push pin, there is a risk of injury.

When the bowl is full, turn off the grinder, dump the minced meat into a larger container, place the bowl back in place and press the start button again. On reversing types, the reversing action can be used to release the stuck auger (Fig. 5). When using the sausage filling attachment, take care not to overfill the grinder and the clogging of the attachment and possible damage to the drive gear.

Never throw bones into the working area, there is a risk of damage to the blade or gears!

Always change blades and dies when the machine is switched off and disconnected otherwise there is a risk of injury (Fig. 2).

Replacement is carried out by loosening the steel nut (I) on the mill face and removing the individual working parts (die, blade and screw, see Figures 2,3,6,7) one by one. When reassembling the individual parts, ensure that they are correctly seated. Incorrect seating can damage the machine.

When delivered, the meat grinders are equipped with a worm, a cutting knife and a die with 6 mm diameter holes. When grinding meat on matrices with smaller hole diameters, it is necessary to pre-grind the raw material on a matrix with a hole diameter of 6 mm or larger!

When grinding raw material on a matrix with a small hole diameter without prior pre-grinding, there is a risk of overloading the machine and consequently breaking the blade shaft!

When using a double-fold grinder (models TS-12D, TE-22D, TS-22D and TS-32D), follow Figures 2 and 3 for disassembly and reassembly. All parts of a single or double composition are unique and cannot be interchanged. Failure to follow the sequence of the parts may result in damage to the parts or damage to the machine!

All ground raw materials must contain fat, which serves to lubricate the worm gear. Never grind cooked meat, there is a risk of jamming the machine. Do not clean the grinding chamber with baked goods - there is a risk of damaging the machine (breaking the blade shaft).

Use the TE and TS mills by applying processing cycles that include operating time under load and rest time (10 minutes of operation and 15 minutes of rest).

Combination of matrices for double composition

Models			
TS-12D	0 + 6 + 2,5	0 + 6 + 3	0 + 8 + 3,5
TE, TS-22D	0 + 6 + 2	0 + 6 + 3	0 + 8 + 4,5
TS-32D	0 + 6 + 3	0 + 8 + 4,5	

The number indicates the hole in mm

The number 0 indicates a knife with three holes in a double composition

Fig. 2 Disassembly of the two-composition non-remo-

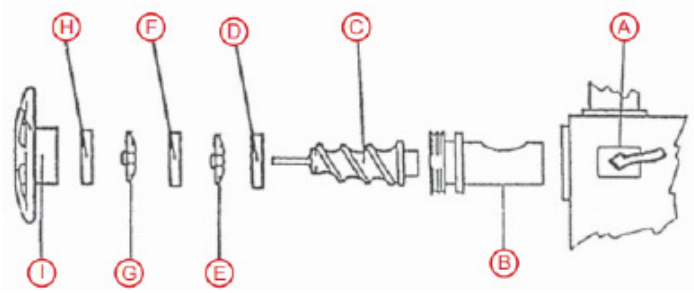

- A) Chamber housing
- B) Grinding chamber
- C) Snail
- D) Dividing matrix
- E) Rear knife
- F) Matrices
- G) Front knife

Fig. 3 Disassembly of two-composition detachable head

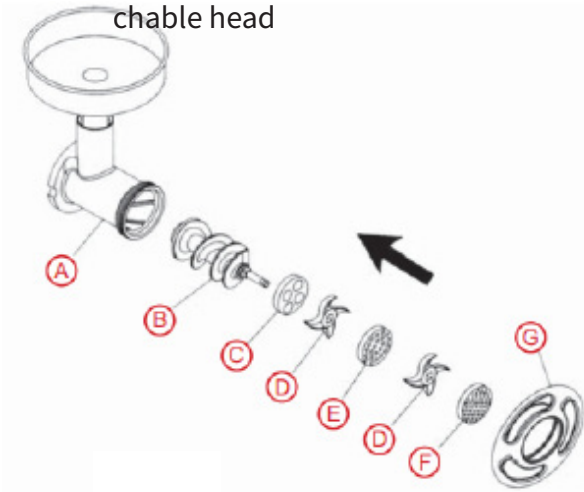

- A) Grinding chamber
- B) Snail
- C) Dividing matrix
- D) Knife
- E) Matrices
- F) Matrices
- G) Matrices

Fig. 4



Fig. 5



A) FORWARD button

B) STOP button

C) Cause button

The TS-22 and TS-32 can be used for to release the stuck cutting mechanism, use the re-verse gear.

Fig. 6 Disassembly of the one-piece non-removable head

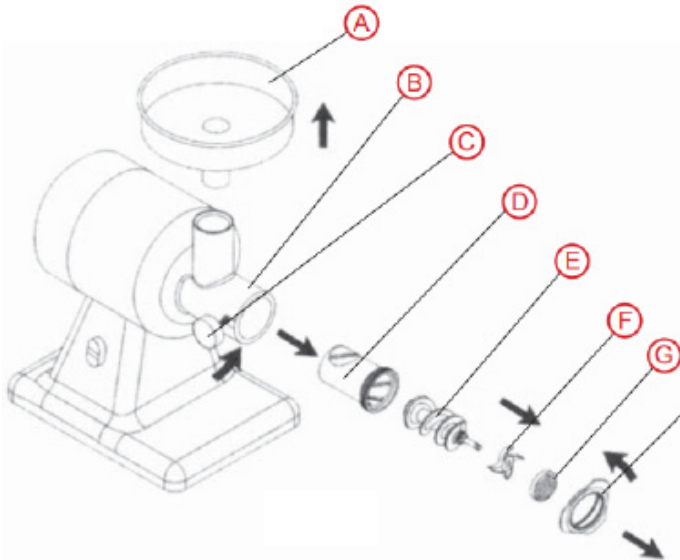

A) Hopper

B) Chamber body

C) Locking screw

D) Grinding chamber

E) Snail

F) Knife

G) Matrices

H) Matrix

Fig. 7 Disassembly of the one-piece detachable head

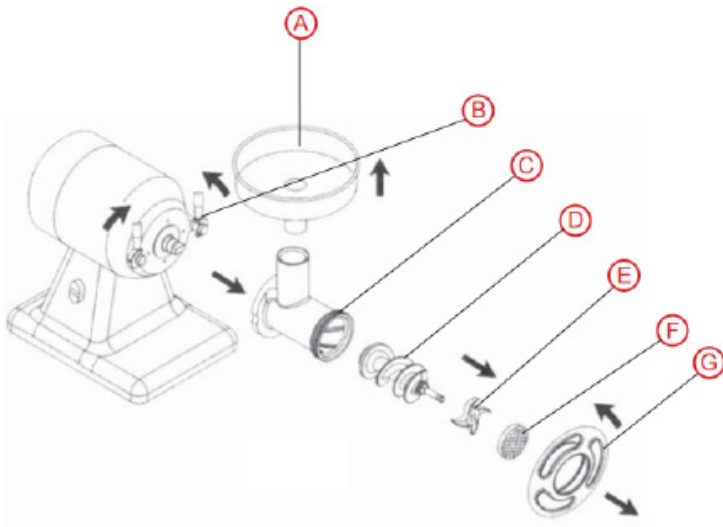

- A) Hopper
- B) Locking lever
- C) Grinding chamber
- D) Snail
- E) Knife
- F) Matrices
- G) Matrix

Fig. 8



Decomposed TE Decomposed TE 22

Fig. 9



T-8

8. CLEANING AND MAINTENANCE

It is recommended to have the device checked with a specialist service at least once a year. All the interventions in the device can only be carried out by a qualified person who has the authorization to do so. **CAUTION!** The device must not be cleaned with direct or pressure water. Clean the equipment daily. Daily maintenance extends the life and efficiency of the equipment. Always turn off the main inlet to the device. Wash the stainless steel parts with a damp cloth with a detergent without coarse particles and wipe dry. Do not use abrasive or corrosive cleaning agents. Attention! Before using the device, it is necessary to remove the protective foil from the entire surface, and then wash it well with water with detergent, and then wipe it with a damp cloth. **ALERT!** The warranty does not apply to all consumables subject to normal wear (rubber seals, bulbs, glass and plastic parts, etc.). The warranty also does not apply to the device if the installation is not carried out in accordance with the instructions - an authorized worker according to the corresponding standards and if the equipment was unprofessionally manipulated (interventions in the internal equipment, etc.) or were operated by unhappy staff and contrary to the instructions for use, further The warranty does not apply to damage by natural effects or other external intervention. **Required service organization 2 times a year. After the lifetime, the shipping packaging and equipment are submitted to the collection, according to the regulations on waste management and hazardous waste.**